

POWERKING®

Breaking New Grounds Since 1998

HIDROMEK®

HMK 102S BACKHOE LOADER



maestro
SERIES

ENGINE

Make	: PERKINS
Type	: 110 4D-44TA Diesel Engine
Number of Cylinders	: 4 in line
Bore & Stroke	: 105 x 127 mm
Displacement	: 4400 cm ³
Maximum Power	: 74.5 kW, 100 HP (2200 rpm)
Maximum Torque	: 400 Nm (1400 rpm)

High power and torque output, water cooled turbocharged diesel engine

Compatible with USA EPA Tier 3 and European EC Stage III-A exhaust gas emission regulations

HYDRAULIC SYSTEM

Simple, reliable and high-efficient tandem gear pump

Main Pump Flow	: 90 lt/min (2200 rpm)
Pressure	: 230 bar
Auxiliary Pump Flow	: 64 lt/min (2200 rpm)
Pressure	: 210 bar

DRIVING SPEEDS

At 2200 rpm engine speed

1 st gear	: 6	km/h
2 nd gear	: 11.5	km/h
3 rd gear	: 17	km/h
4 th gear	: 27	km/h
5 th gear	: 40	km/h

CAB & HOOD

- Aesthetics
- Widened Visual Angle
- Spacious Interior
- Ergonomic & Esthetic Interior Design
- Ergonomic Controls and Hand Brake
- Improved Ventilating and Air-conditioning System
- Rops and Fobs Certified
- Multi-functional Seat
- Adjustable Steering Wheel
- Ergonomic & Elegant Hand Throttle
- Panoramic View by Large Glass Windows
- Ease of service maintenance
- Easy detachable front window blind
- Impact resistant single piece casting tip



TRANSMISSION

- Autoshift ZF transmission for heavy duty service
- Torque converter with 2,87: 1 stall ratio
- Electrically controlled 2 Wheel Drive or 4 Wheel Drive selection
- 5 forward, 3 reverse gears

STEERING

Electrical controlled 3 different steering modes

- A 2 - wheel front steering for road drive
- B 4 - wheel steering for tight turns
- C 4 - wheel "crab" steering for close - to wall digging and ditch closing

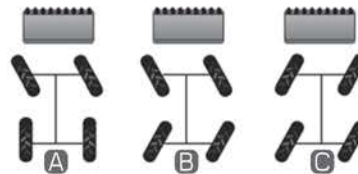

AXLES

- Heavy duty service type
- Planetary outboard type reduction gears
- Total 16° oscillation on the front axle

TIRES

Front, Rear : 16.9 - 28 12 Ply rating

OPERATING WEIGHT

Operating weight (with standard equipment) : 9150 kg
Operating weight (with telescopic boom) : 9300 kg

www.hidromek.com

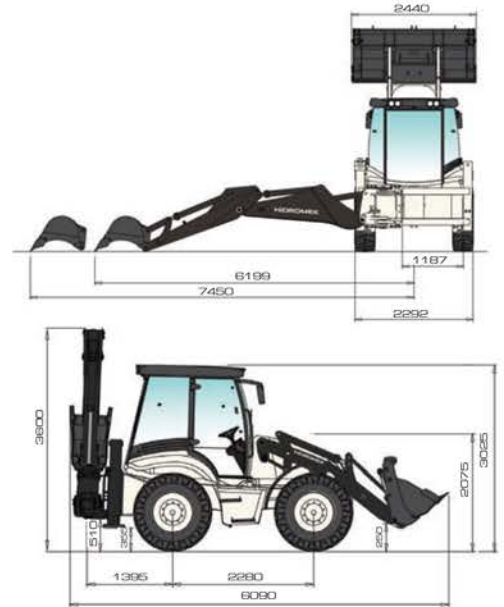
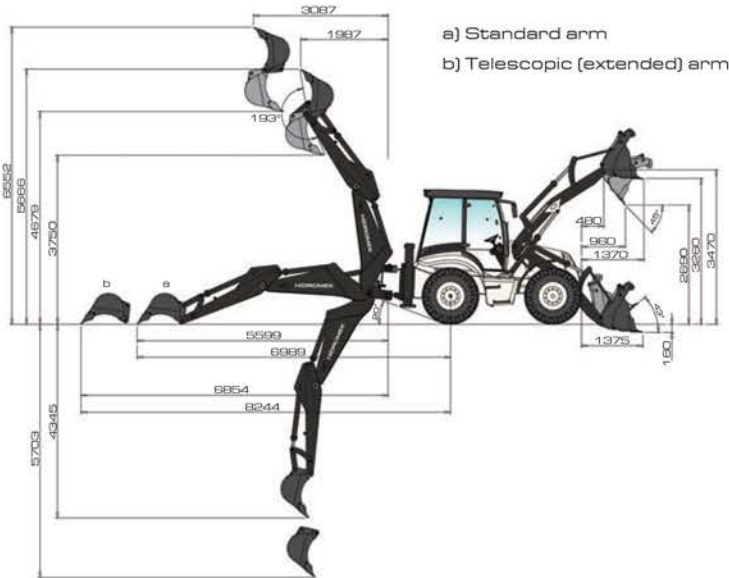

HMK102S **maestro** SERIES







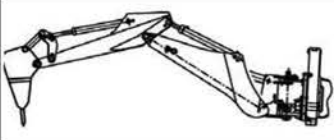
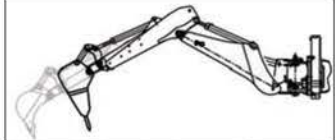
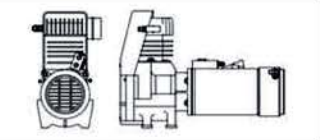
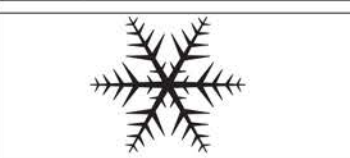

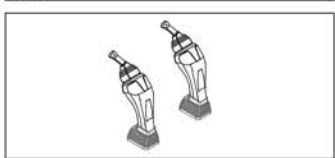
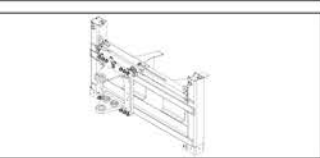

LOADER PERFORMANCE	
4 in 1 bucket capacity m ³	1.1
Max. bucket breakout force kgf	7203
Max. loading arm breakout force kgf	6513
Lifting capacity to maximum height kg	3016
Maximum lifting capacity 7'4"	3992
Maximum lifting capacity 7'8"	3923

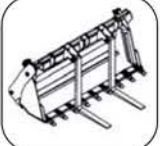
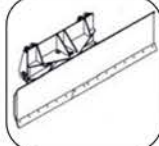
BACKHOE PERFORMANCE	Standard Arm	Telescopic Arm (extended)	Telescopic Arm (retracted)
Bucket Capacity	0.17 m ³	0.17 m ³	0.17 m ³
Max. bucket breakout force	6209 kgf	6358 kgf	6358 kgf
Max. dipper breakout force	2983 kgf	2022 kgf	2859 kgf
Lifting capacity to maximum height	1772 kg	956 kg	1572 kg

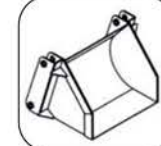
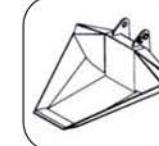
Accessories

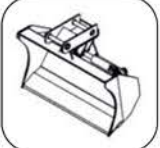
 Telescopic arm	 Hydraulic breaker installation	 Hydraulic breaker inst. + Telescopic arm	 Air Compressor
 Air conditioner	 MSS (Motion Stabilizer System)	 Joystick	 Powerslide

Attachments

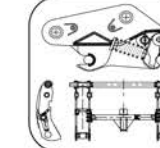
 4-in-1 Bucket with forks	 Grading blade	 Timber grab	 Special buckets	 Trapezoidal ditch bucket	 Ripper
 Offset bucket	 Clamshell grab	 Backhoe bucket of different sizes	 Hydraulic breaker	 Auger	 Quick coupler

OPTIONAL

[EN] March 2012



Corporate Headquarters:
POWERKING
 476 Edsa, Caloocan City
 Tel. No.: **+632 364-6092**
 Fax. No.: **+632 365-7460**
 Email: sales@powerking.com.ph
www.powerking.com.ph

Regional Offices:
POWERKING
Subic
 Lot3, Baton Area, Subic District,
 Argonaut Highway, Subic Bay
 Freeport Zone
 Tel. No.: **(047) 250-2331**

POWERKING
Cebu City
 Ridgedale Subdivision
 Tac-an Road, Talamban,
 Cebu City
 Tel. No.: **(02) 364-6092** (Manila)

POWERKING
Cagayan De Oro
 National Highway, Brgy. Ipit,
 Municipality of Opol,
 Misamis Oriental
 Tel. No.: **(088) 305-0032**