

MB-L140 S2

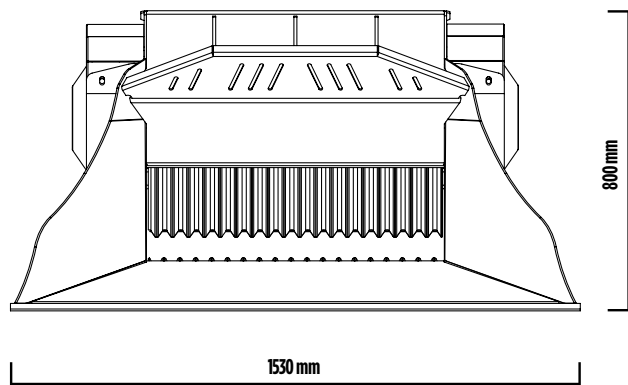

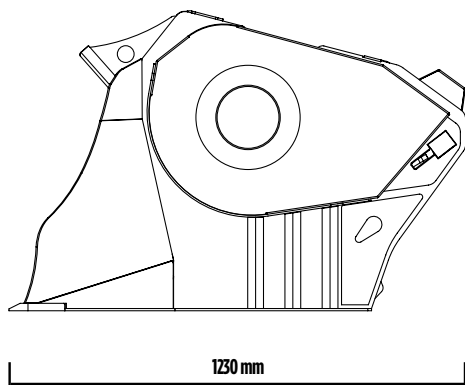
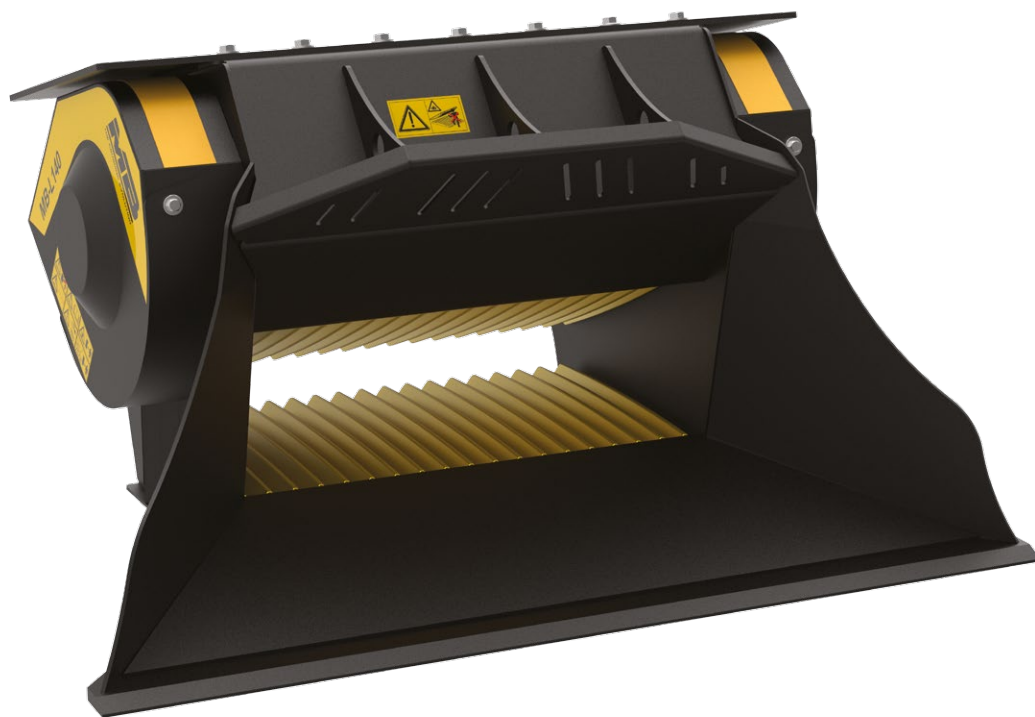

MB-L140 S2

The MB-L140 crusher bucket is the most versatile in the MB-L range and adapts to the majority of heavy equipment. Compact and easy to handle, it offers very high standards of productivity and quality. The MB-L140 model combines the technical characteristics of a crusher bucket with the practicality of a compact attachment.





ACCESSORIES

- RECOMMENDED SPARE PARTS KIT
- HOUR METER
- DUST SUPPRESSION KIT
- 24 MONTHS WARRANTY

AREAS OF APPLICATION

- RECYCLING
- MEDIUM-SCALE RESIDENTIAL WORKSITES
- SMALL-SCALE COMMERCIAL WORKSITES
- SMALL DEMOLITION SITES

SPECIFICATIONS

EQUIPMENT	LOAD CAPACITY	OPENING DIMENSIONS	OUTPUT SETTING	DIMENSIONS
 ≥ 3 Ton	0,25 m ³	L 740 H 250 mm	≥ 15 ≤ 60 mm	1230 x 1530 H 800 mm
 ≥ 6 ≤ 8 Ton				
OIL FLOW	PRESSURE	COUNTER PRESSURE	WEIGHT	MAXIMUM PRODUCTION
98 l/min.	200 bar	20 bar	0,98 Ton	16 m ³ /h